

Roxtec UG™ solutions

CABLE ENTRY SEALS FOR UNDERGROUND APPLICATIONS IN THE POWER INDUSTRY

Long-lasting barrier

Roxtec UG solutions are designed for underground applications where there is a need for sealing against constant water pressure. This product family is ideal for power cables entering building structures via foundations.

Excellent protection

The products are specifically developed to be used in underground applications where fire is not an issue. The seals

are designed to be resistant to constant as well as catastrophic water pressure. You can use them to eliminate flooding and prevent humidity from damaging equipment.

Smart knock-out sleeve

The innovative knock-out sleeve is designed to be cast into the foundation. It provides spare capacity for additional installations and future expansion.

WHY USE ROXTEC?

- Easy to design in and install
- Corrosion and rodent resistant
- Eliminate flooding and prevent humidity from damaging equipment
- Multidiameter™ by Roxtec – adapts through modules with removable layers
- Pull-out tests performed

Roxtec H3 UG™ seal

The openable Roxtec H3 UG seal is ready for direct routing of cables in trefoil formations. The seals are IP68 rated and verified for constant pressure.

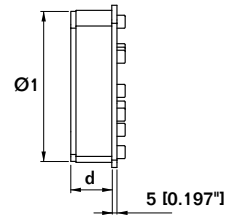
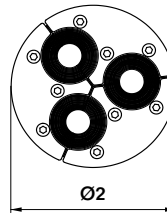

Stainless steel

Article	Number of cables	For cable/pipe Ø (mm/")	For aperture dimension Ø (mm/")	d (mm/")	Ø1 (mm/")	Ø2 (mm/")	Weight (kg) (lb)	Art. no
H3-150 UG	3	24-52/0.945-2.047	150-152/5.906-5.984	40/1.575	150/5.906	160/6.299	1.8/4.1	117843
H3-150 UG woc	3	24-52/0.945-2.047	150-152/5.906-5.984	40/1.575	150/5.906	160/6.299	1.6/3.4	108586
H3-200 UG	3	48-68/1.890-2.677	200-202/7.874-7.953	65/2.559	200/7.874	210/8.268	4.3/9.5	117842
H3-200 UG woc	3	48-68/1.890-2.677	200-202/7.874-7.953	65/2.559	200/7.874	210/8.268	3.8/8.4	108697

Note: woc = without core

Roxtec C R UG™ and R UG™ kits

The frames are used with UG modules that are easy to adapt to cables and pipes of different sizes. The seals are IP68 rated and verified for constant pressure.

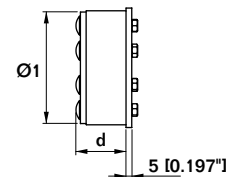
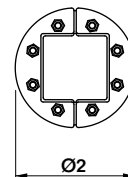

Stainless steel

Article	For aperture dimension Ø (mm/")	Multidiameter range and number of cables					Art. no
		0+4-13 mm 0+0.157-0.512" (RM/CM 20 UG)	0+4-13 mm 0+0.157-0.512" (RM/CM 20w40 UG)	0+10-23.5 mm 0+0.394-0.925" (RM/CM 30 UG)	0+9.5-31 mm 0+0.374-1.220" (RM/CM 40 UG)	0+24-52 mm 0+0.945-2.047" (RM 60 UG)	
C R 100/4 UG	100-102/3.937-4.016			4 cables/pipes			117844
C R 100/6 UG	100-102/3.937-4.016	1 cable/pipe	4 cables/pipes		1 cable/pipe		117845
R 150/6 UG	150-152/5.906-5.984			5 cables/pipes		1 cable/pipe	120859
R 150/9 UG	150-152/5.906-5.984			9 cables/pipes			117821
R 200/4 UG	200-202/7.874-7.953					4 cables/pipes	117822
R 200/7 UG	200-202/7.874-7.953			4 cables/pipes		3 cables/pipes	117854
R 200/15 UG	200-202/7.874-7.953		8 cables/pipes		7 cables/pipes		117855

Note: The black colored UG modules have their own range of Multidiameter™.

Roxtec knock-out sleeve UG™

– READY FOR EXPANSION

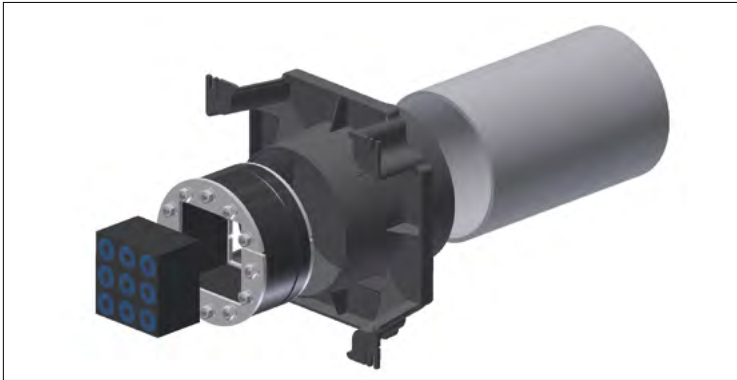

The sleeves with knock-out plates form an efficient barrier today while providing built-in spare capacity for tomorrow. The sleeves are available in three different standard industry sizes and are designed to fit Roxtec UG seals and frames.

Easy to cast into foundation

You can easily fasten the sleeves to the casting molds prior to the casting of the foundation. They fit perfectly in molds for wall thicknesses of 150 mm, but you can also adapt them by cutting the sleeve or adding a conduit pipe on one end.

Flexible combinations

The sleeves can be used in many combinations. By installing the knock-out sleeves you can be sure to have a tight seal also during transportation to the site.

WHY USE ROXTEC?

- Future capacity included
- Available in three sizes
- Easy to adapt and use
- Select your own combination
- Keeping tight underground

Disclaimer: The casting process must be made with craftsmanship and in accordance with the environmental conditions expected in terms of mix and preparations.

Roxtec knock-out sleeves UG™

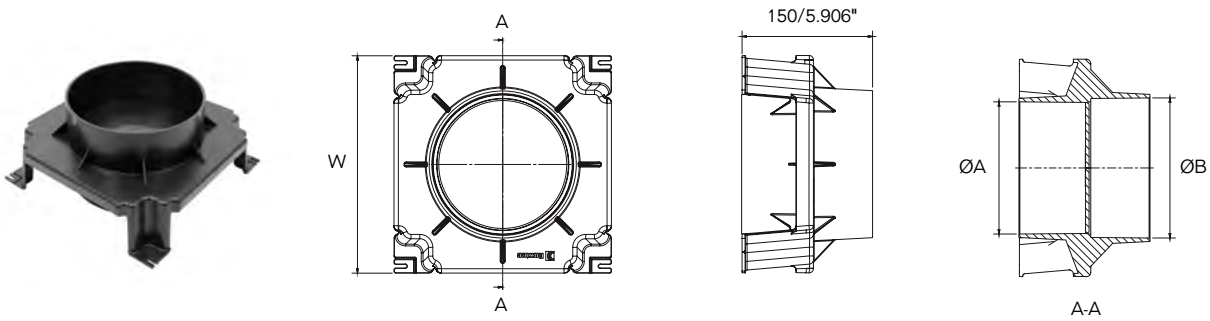

Plastic

Article	W (mm/")	Ø A (mm/")	Ø B (mm/")	Accommodates seal	Accommodates conduit (mm/")	Art. no
KOS 100/110 UG	200/7.874	102/4.016	111/4.370	C R 100 UG	110/4.331	111825
KOS 150/160 UG	250/9.843	152/5.984	161/6.339	R 150 UG H3-150 UG	160/6.299	111824
KOS 200/200 UG	300/11.811	202/7.953	201/7.913	R 200 UG H3-200 UG	200/7.874	111826



Roxtec International AB
 Box 540, 371 23 Karlskrona, SWEDEN
 PHONE +46 455 36 67 00, FAX +46 455 820 12
 EMAIL info@roxtec.com, www.roxtec.com